

Photoelectrics Through-beam, Transistor Output Type PE12C.T15..

CARLO GAVAZZI



- Elevators, Escalators and Entrance control
- Range 15 m
- Modulated, infrared light
- Supply voltage: 10 to 30 VDC
- Output: 100 mA, NPN or PNP type
- Make or break switching
- LED for output indication or power supply
- Protection: reverse polarity, short circuit, transients
- Cable versions with or without connector
- Emitter mute and power adjustment
- High neighbour immunity, 3-codes
- CE, UL325 and UL508 approved



Product Description

The PE12C.T15. is a family of general purpose Photoelectric sensors. They are specially designed for Elevators, Escalators, Entrance control to meet the requirements in the door market. The "snap-on" housing can be mounted with a wall thickness from

0.6 mm to 2.25 mm. The emitter has a mute input to turn it off for evaluation of the sensor function. The emitter and receivers can be delivered in 3 different codes on order to improve neighbour immunity. Available in 10-30 VDC version.

Ordering Key

PE12C1T15NO-C2

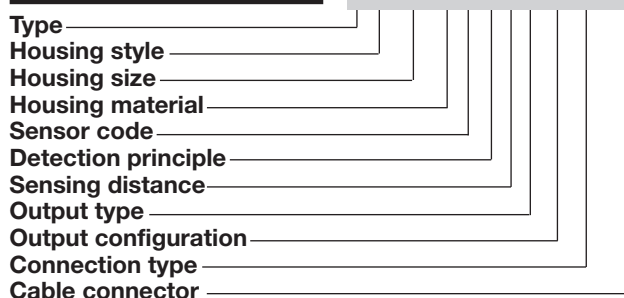

Type Selection

Housing diameter	Range S _n	Con- nec- tor	Ordering no. Receiver NPN, NO	Ordering no. Receiver NPN, NC	Ordering no. Receiver PNP, NO	Ordering no. Receiver PNP, NC	Ordering no. Emitter
Ø 12 mm Code 1	15 m	NO	PE12C1T15NO	PE12C1T15NC	PE12C1T15PO	PE12C1T15PC	PE12C1T15
Ø 12 mm Code 2	15 m	NO	PE12C2T15NO	PE12C2T15NC	PE12C2T15PO	PE12C2T15PC	PE12C2T15
Ø 12 mm Code 3	15 m	NO	PE12C3T15NO	PE12C3T15NC	PE12C3T15PO	PE12C3T15PC	PE12C3T15
Ø 12 mm Code 1	15 m	YES	PE12C1T15NO-C2	PE12C1T15NC-C2	PE12C1T15PO-C2	PE12C1T15NC-C2	PE12C1T15-C2
Ø 12 mm Code 2	15 m	YES	PE12C2T15NO-C2	PE12C2T15NC-C2	PE12C2T15PO-C2	PE12C2T15NC-C2	PE12C2T15-C2
Ø 12 mm Code 3	15 m	YES	PE12C3T15NO-C2	PE12C3T15NC-C2	PE12C3T15PO-C2	PE12C3T15NC-C2	PE12C3T15-C2

Note: Please order emitter and receiver separately

Specifications Emitter

Rated operational volt. (U _B)	10 to 30 VDC	Light source	LED, 880 nm
Ripple (U _{rrp})	≤ 10%	Light type	Infrared, modulated
Supply current	≤ 20 mA	Optical angle	± 5°
Protection	Reverse polarity, transients	Indication function	Power supply ON Mute input ON
Control input		Power adjustment	LED, green LED, green flashing
Normal oper.	> 1.5 VDC	R _x ~ 3 kΩ -10 kΩ	0 - 100%, in 20 step
Mute	< 1.2 VDC		

Specifications Receiver

Rated operating dist. (S_n)	15 m	Optical angle	$\pm 5^\circ$
Blind zone	None	OFF-state current (I_r)	$\leq 100 \mu\text{A}$
Temperature drift	$\leq 0.4\%/^\circ\text{C}$	Voltage drop (U_d)	$\leq 1.6 \text{ VDC @ } 100 \text{ mA}$
Hysteresis (H)	3 - 20%	Protection	Short-circuit, reverse polarity, transients
Rated operational volt. (U_B)	10 to 30 VDC (ripple included)	Operating frequency (f)	100 Hz
Ripple (U_{rrp})	$\leq 10\%$	Response time	OFF-ON (t_{ON}) $\approx 3.5 \text{ ms}$ ON-OFF (t_{OFF}) $\approx 6.5 \text{ ms}$
Output current		Power ON delay (t_v)	$\leq 300 \text{ ms}$
Continuous (I_o)	$\leq 100 \text{ mA}$	Output function	NPN or PNP
Short-time (I)	$\leq 100 \text{ mA}$, (max. load capacity 100 nF)		Make or break (NO or NC)
No load supply current (I_o)	$\leq 16 \text{ mA}$	Indication function	Output ON
Minimum operational current (I_m)	0.5 mA		LED, yellow
Ambient light	$>20.000 \text{ LUX}$		

General Specifications

Environment		Housing material	
Overvoltage category	II (IEC 60664/60664A, 60947-1)	Body PE12	PC black
Pollution degree	3 (IEC 60664/60664A, 60947-1)	Front glass	PC black
Degree of protection	IP 67 (IEC 60529, 60947-1)	Connection	
Temperature		Cable	PVC, TX: grey / RX: black, 5 m, 3 x 0.14 mm ² , $\varnothing 2.9 \text{ mm}$
Operating	-20° to +50°C (-4° to +122°F)	Weight	
Storage	-25° to +80°C (-13° to +176°F)	Emitter	80 g
Vibration	10 to 150 Hz, 0.5 mm/7.5 g (IEC 60068-2-6)	Receiver	80 g
Shock	2 x 1 m & 100 x 0.5 m (IEC 60068-2-32)	CE-marking	EN12445, EN12453, EN12978
Rated insulation voltage	50 VDC	UL-Approval	cULus UL325, CSA-C22.2 No.247 cULus UL508

Operation Diagram

t_v = Power ON delay

Power supply

Target emitter present

Object present

Break (NC) Output ON

Make (NO) Output ON

Mute active $\leq 1.2 \text{ VDC}$

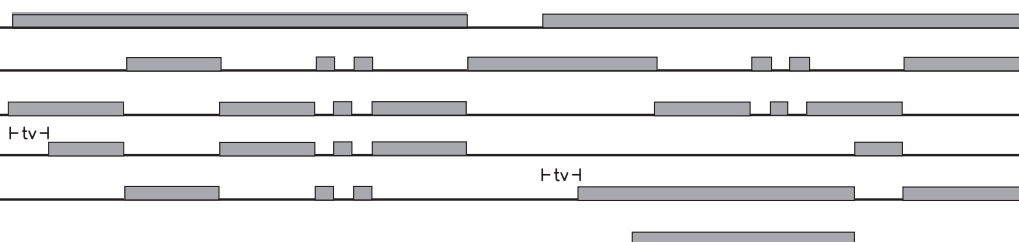

Installation Hints

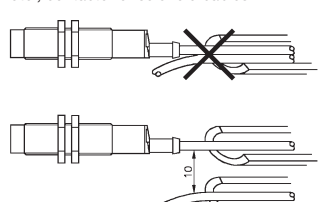
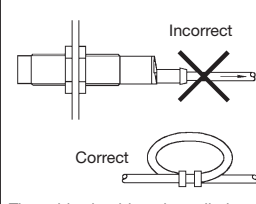
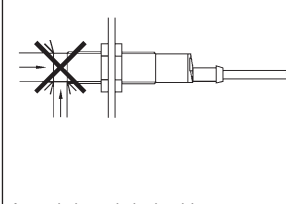
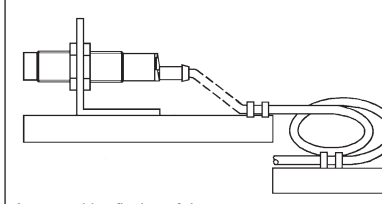
<p>To avoid interference from inductive voltage/current peaks, separate the prox. switch power cables from any other power cables, e.g. motor, contactor or solenoid cables</p> 	<p>Relief of cable strain</p>  <p>The cable should not be pulled</p>	<p>Protection of the sensing face</p>  <p>A proximity switch should not serve as mechanical stop</p>	<p>Switch mounted on mobile carrier</p>  <p>Any repetitive flexing of the cable should be avoided</p>
--	---	---	--

Dimensions

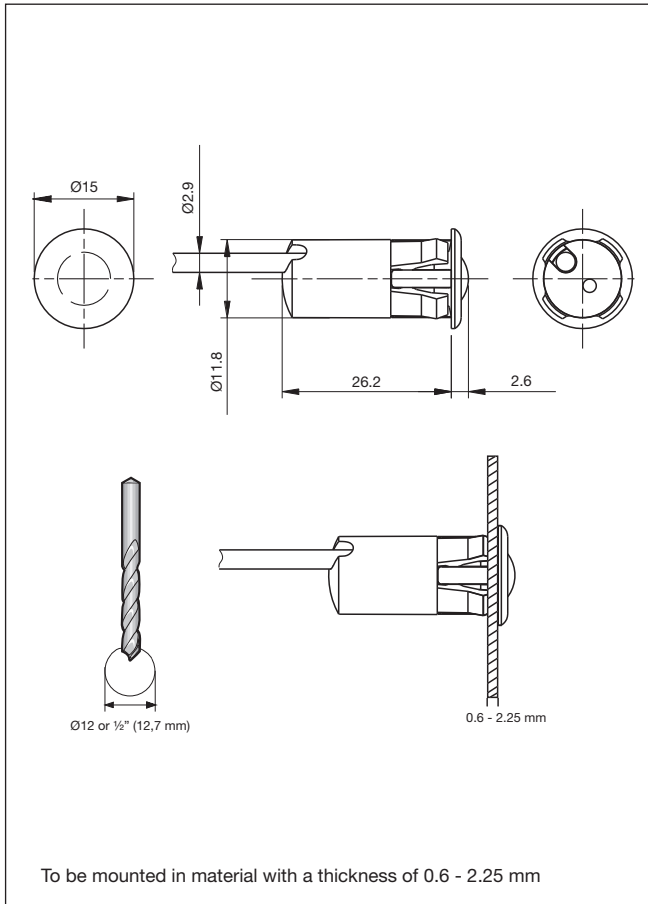

Detection Diagram

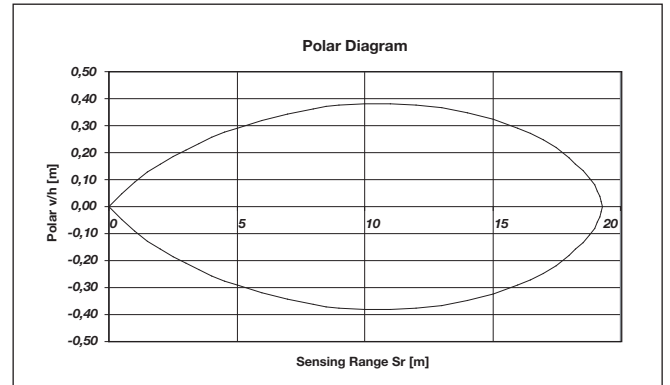

Excess Gain

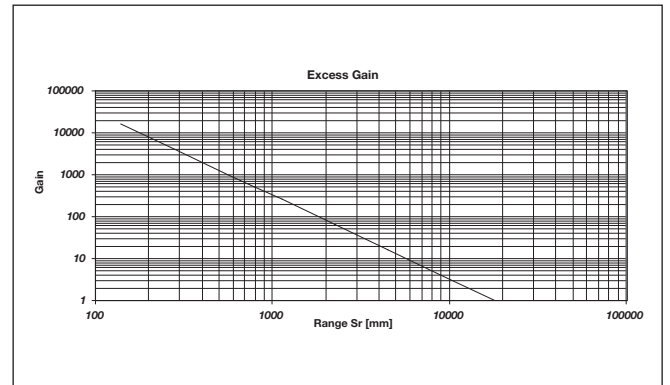

Wiring Diagram

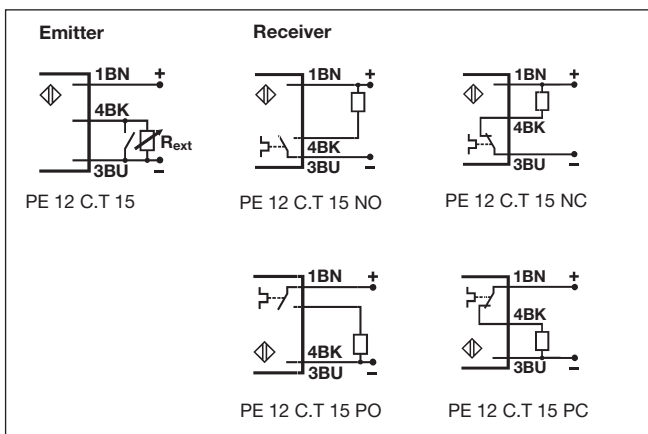

Delivery Contents

- PE12
- Installation instruction
- **Packaging:** plastic bag

Neighbour Immunity Diagram

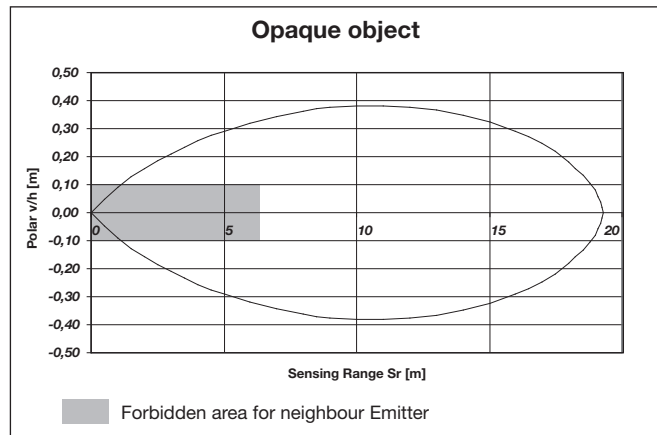
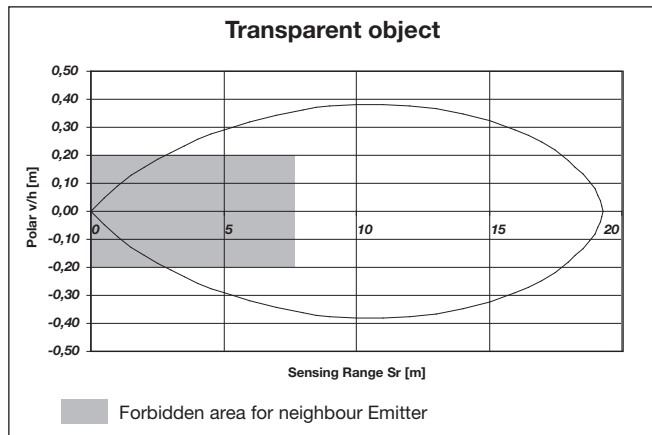

Mute Function

